

CD3312L CD3314L CD3318L

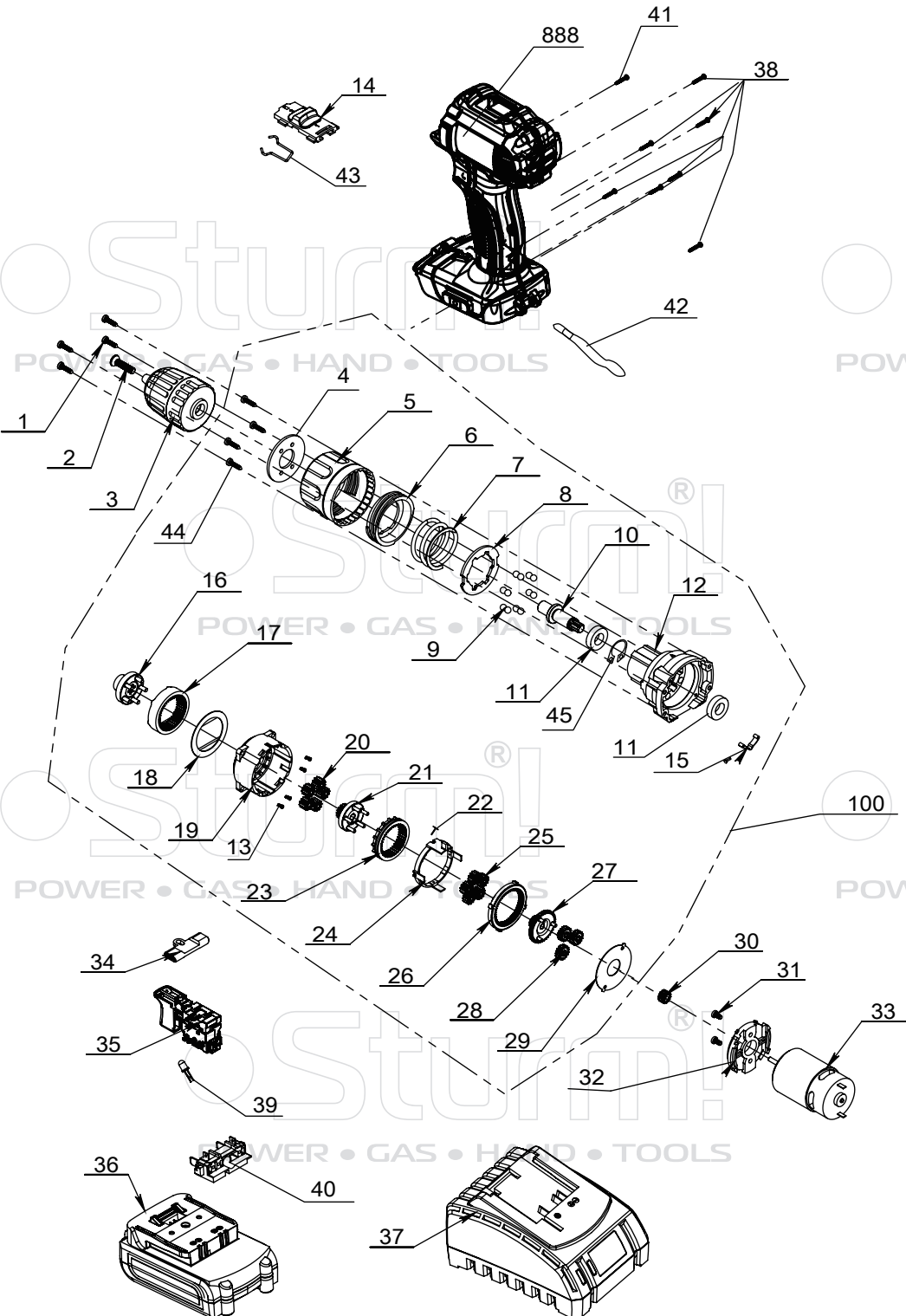

NO.	DESCRIPTION
1	SCREW
2	SCREW
3	KEYLESS CHUCK
4	PRESS BOARD
5	TORQUE SETTING RING
6	INNER THREADED RING
7	SPRING
8	BIG WASHER
9	STEEL BALL
10	SPINDLE
11	BEARING 6800Z
12	FRONT GEAR BOX
13	SCREW
14	TWO SPEED BUTTON
15	TORQUE SETTING SPRING
16	THE THIRD PLANETARY CARRIER
17	GEAR RING
18	WASHER
19	BACK GEAR BOX
20	THE THIRD PLANETARY GEAR
21	THE SECOND PLANETARY CARRIER
22	PIN
23	MOVING RING GEAR
24	MOVING RING GEAR HOLDER
25	THE SECOND PLANETARY GEAR
26	FIXED RING GEAR
27	THE FIRST PLANETARY CARRIER
28	THE FIRST PLANETARY GEAR
29	WASHER
30	MOTOR GEAR
31	SCREW
32	MOTOR FLANGE
33	MOTOR
34	DIRECTION SWITCH
35	SWITCH
36	BATTERY PACK
37	CHARGER
38	SCREW
39	LED
40	CONNECTOR
41	SCREW
42	ROPE
43	SPRING
44	SCREW
45	CIRCLIP
100	GEAR BOX ASSEMBLY
888	HOUSING